

NEW HID

- 140 LANCE
- 170 STRIKER
- 240 BLITZ



PLUS RETRO FIT HID KITS!

WELCOME
FAQ'S
GENESIS
240 XGT
240 HID
140 LANCE
270 STRIKER
240 BLITZ

>Pg 2
>Pg 3
>Pg 4-5
>Pg 6
>Pg 6
>Pg 7
>Pg 7
>Pg 7

HID KITS
FILTER SYSTEM
LUX MEASUREMENT
ACCESSORIES
IMAGE GALLERY
PRODUCT SPECS

>Pg 7
>Pg 8
>Pg 9
>Pg 10
>Pg 11
>Pg 12

LightFORCE™

PERFORMANCE LIGHTING





WELCOME TO LIGHTFORCE COUNTRY

Choosing a quality driving light is a true investment in your on or off-road performance. For over twenty years LIGHTFORCE have been the innovators in Hi-Tec portable lighting equipment. We trust you will find this catalogue helpful and enlightening.

LIGHTFORCE REDEFINED CONVENTION...

WHY CHOOSE LIGHTFORCE?

1: PRODUCT DESIGN & INNOVATION

Understanding market/customer needs and producing benchmark professional standard products.

2: SUPERIOR LIGHT OUTPUT

Achieved by combining mirror like specifically designed reflectors and superior bulb design choice. Whether competing in off-road motorsport or day to day driving, LIGHTFORCE enables you to see further and with less fatigue.

3: STRONG, LIGHTWEIGHT & DURABLE

LIGHTFORCE products are designed ultra tough utilising Hi-Tec composite materials resulting in light weight and extreme structural strength and durability. Ask any owner or long term user of a LIGHTFORCE product. Why would anyone want a heavy weight old-fashioned style light? Long term durability and performance is a win-win scenario for value and reliability.

4: UNIQUE MODULAR FILTER SYSTEM

LIGHTFORCE driving lights are designed to enable you to customise to changing driving conditions in seconds with no tools required! The clip-on filter system is unique and a recognised favourite with the off-road enthusiast and professionals alike.

A MODEL FOR ANY SITUATION

We have a light suitable for a diverse range of vehicles and applications. LIGHTFORCE only makes product to one standard, professional quality.

Consider the following when choosing a driving light.

1: What driving conditions are you likely to encounter?

- Long straight roads (STRIKER™, BLITZ™, XGT, HID, GENESIS)
- Winding roads (LANCE™, STRIKER™, GENESIS)
- Diverse and mixed (STRIKER™, BLITZ™, XGT, GENESIS)
- Rain, fog, snow, dust (Check the clip-on filters)
- Crawling/slow/recovery (LANCE™, STRIKER™ with filters)

2: What mounting limitations do I have on my vehicle?

We have a range of sizes with effective reflector diameters that outperform all others. Remember, LIGHTFORCE gives you the option to customise the beam colour and or pattern to suit ever changing driving conditions.

THE VIDEO THAT SAYS IT ALL

If a picture is worth a thousand words, wait until you see the LIGHTFORCE video. This test was conducted in a police ballistics facility and leaves but one conclusion. LIGHTFORCE can withstand brutal impacts like no other light on the market. That means your light has a chance of surviving off-road incidents and being ready for use when you need it. Think about it, could any other brand light withstand this type of extreme abuse?

Some say this test is overly extreme and beyond what is reasonable but any experienced off-road enthusiast knows how fragile most lights (even toughened glass and metal) can be under rock, brush or other impacts. We do not claim to be unbreakable but any LIGHTFORCE light is more likely to survive these inevitable incidents and remain operational.

If you have not seen this video, go to: WWW.YOUTUBE.COM and just look for **LIGHT LOGIC** in the search function.

Pure performance and long term durability has earned us customer loyalty from all corners of the globe.



Can you think of any other light that could withstand the full blown swing from a baseball bat? No old fashioned toughened glass or metal here.



At a police range we used a standard issue Remington® 870 with #7 lead shot at 15 yards. The shot you see here is ricocheting off the filter at over 1000 fps. Let us be clear, we are not claiming our lights are bulletproof but we will say LIGHTFORCE has forged an unrivalled international reputation for durability!



READ THIS & BECOME A LIGHT EXPERT

Some of these facts may surprise you and challenge common beliefs. The result of our unique design philosophy is a product that outshines and outlasts lesser lights. Don't be misled. There is a new way, a new era and LIGHTFORCE are the innovators.

A LITTLE 'LIGHT' READING WORTH YOUR LEARNING

"Surely a plastic light can't be as strong as a metal one? So it's lightweight. What's the advantage of that?"

ANSWER: LIGHTFORCE is more than just another 'plastic' light, we pioneered the use of Hi-Tec composites in lighting equipment. Consider how materials have evolved in the automotive and aviation industry sector. Lighter and stronger than steel or old fashioned convention and new levels of performance previously not thought possible. LIGHTFORCE set a new benchmark in strength and durability that became legendary. Vulnerable glass and or heavy metal is just illogical, especially in off-road motor sport! Ask any knowledgeable fabricator, if he/she can have an item of equal strength or even stronger for less weight, what would they choose? A resounding "YES PLEASE!". Think of a CLASS 1, TROPHY TRUCK or sand rail with typically 8-10 HID lights, the majority mounted on the roof. Why add unnecessary weight in such a handling dynamic sensitive area? This is where LIGHTFORCE is the answer, plus light output that is unsurpassed.

"I've heard plastic lights vibrate off-road and fatigue in the sun or extreme cold?"

ANSWER: On the contrary, a heavy metal light is far more likely to vibrate, indeed metal lights are known to crack under harmonic fatigue in extreme situations. Vibration can also be a result of a poor mounting point or a vehicle that is prone to this dynamic. If the mounting point is vibrating, anything attached will as well! Your LIGHTFORCE light should be torqued to 50ft/lbs - 68nm at the mounting point and if everything is solid you should have no issues. We use UV stabilised materials that are inert to weather or real operating conditions. LIGHTFORCE is known for its durability from below -30°C to the scorching heat and dust of the Australian outback and other extreme desert conditions. A little known fact is how extreme cold can cause conventional lights to crack, even the metal components. Alaska and Sweden are two markets where LIGHTFORCE has forged a formidable reputation where only the toughest products survive.

"I have a 130 watt bulb in my light. How can a LIGHTFORCE light be any brighter? What do you mean by rating your light output by LUX?"

ANSWER: Wattage alone can be very misleading. It's all about how the power is being utilised by the bulb, the more efficient the bulb, the more light. A huge disadvantage besides high amperage draw on your electrical system is the immense heat output of high wattage bulbs. Stories abound of people either melting or burning light housings or cracking hot glass lenses when suddenly subjected to water. Light output is obviously a combination of the bulb, the reflector and lens, it is far more than just wattage or over hyped candlepower! This is one reason why at LIGHTFORCE we choose to rate our light output at a 1 LUX reading to demonstrate a REAL maximum distance potential. LUX you ask? Well, 1 lux is considered enough light to read a newspaper. We like LUX as it gives a logical performance benchmark.

"Tell me about this modular filter system? They look like they are just a plastic cover? Surely they will just shatter or crack with a severe impact?"

ANSWER: As standard all current LIGHTFORCE driving lights are supplied with a CLEAR SPOT CLIP-ON filter. All LIGHTFORCE driving lights are designed to be run at all times with a filter in place. We use polycarbonate as used in fighter aircraft canopies, security screens etc. If you have any doubts about durability just check our 'LIGHT LOGIC' video! Literally thousands of people worldwide have stared in disbelief when we display this at trade shows. The filters install with no tools required and in seconds you can change the beam pattern and or colour to suit your situation. Customers tell us how much they love this feature! Check for yourself on many offroad internet forums. Fog, rain, snow, desert silt or Australian bulldust you have the ideal solution at hand!

"Is the LIGHTFORCE light I buy the same as you sell to the off-road race community?"

ANSWER: Absolutely! A crucial part of our success and product development has been our relationship with racers worldwide. The benefit to the consumer is a superior product via our product development and racer feedback. A true win-win scenario.

"Every driving light I have ever seen gets water inside it. What about LIGHTFORCE?"

ANSWER: Every LIGHTFORCE light is fitted with a MIL-SPEC Gore-tex® breather (IP57/67/68/IP69K) to minimize ingress of either moisture or other potential contaminant. The majority of lights in the market place have no effective system to deal with water submersion, humidity or dust. Why compromise?

"What makes the LIGHTFORCE 240 HID so special compared to others?"

ANSWER: From its 2001 Baja victory with Team Hummer, the 240 HID set a new benchmark in HID lighting. Almost half the weight of its closest rival and greater light intensity by virtue of its larger parabolic reflector. It also incorporates the Gore-tex® filter, so no problems with dust or water ingress. Our internal ballast negates the hassle of external mounting. True plug 'n play convenience. Included are billet focal spacer rings to allow you to broaden or tighten the beam pattern. If you are seeking the ultimate in long range performance and reliability for your vehicle, this is it. The Finke Desert race, Baja 500 or 1000 or Dakar? Not all HID lights are equal. The LIGHTFORCE 240 HID is 'King of the Hill'.

"Are LIGHTFORCE lights suitable for ATV's, motorbikes, snowmobiles etc?"

ANSWER: Absolutely! The lightweight and durability factor makes them the logical choice! In extreme conditions we have no equal. Plus all the modular filter versatility to give you maximum visibility.

"Do you make an HID with a really blue or purple output? I want the brightest light!"

ANSWER: Contrary to advertising hype the trend towards even bluer almost purple color output beyond the 6000k+ range does not allow you to see further. **INFACT IT IS COMPLETELY THE OPPOSITE AND SCIENCE DOES NOT LIE!** The 'K' (kelvin) rating is inversely proportional to the light output, therefore the lower the 'K' the brighter the light output. At LIGHTFORCE we choose proven performance over bling with no exceptions. Don't be misled!

"Why is a LIGHTFORCE halogen bulb so bright compared to other brands?"

ANSWER: Our 12V halogen type bulbs incorporate xenon gas enabling them to burn between 10-20% brighter and whiter than conventional halogen bulbs. At 12V they are rated at 2000 hours run time. Ask any other manufacturer what they rate at? Worldwide, professionals who drive at night in the trucking industry tell us the huge benefit they have made changing to LIGHTFORCE in running costs alone.

"Can I install and wire the lights myself?"

ANSWER: We can supply an optional LIGHTFORCE wiring harness that will ensure maximum performance and long term reliability. Anyone with basic mechanical knowledge can carry out an installation although a professional often has the many extra tools and knowledge of individual vehicles to ensure the job is done right.

"Are LIGHTFORCE lights legal on my vehicle?"

ANSWER: We advise you to check with your local authorities, particularly for on-road use. Black, opaque covers are available which may satisfy some jurisdictions for highway use.

WITNESS THE REVOLUTION

Destiny was certain from the beginning.
Genesis had to be the ultimate system for the extreme
operating conditions in every theatre of off-road motor sport.

We listened to fabricators, drivers and our customers,
we dreamed and we created.

Mark this point in time.
Genesis is going to rewrite history on the world stage.

As a result, Genesis's pedigree makes it the natural choice
for just about any vehicle type or usage.

Brilliant design, performance and value.
Why compromise? You deserve it.



GENESIS

MODULAR LIGHTING SYSTEM

THE FUTURE IS YOURS TO SEE

We took into account every desirable feature and performance parameter. Combined with innovation, GENESIS delivers epic performance. Equally at home on any vehicle with all the benefits and kudos of its race heritage and pedigree.

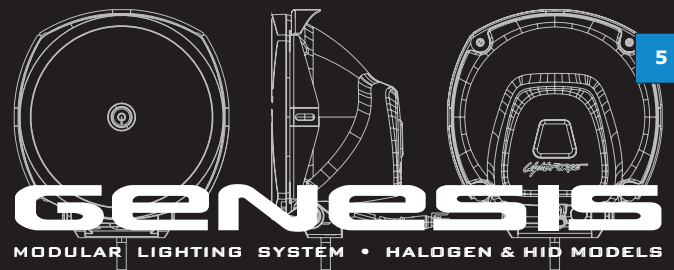

THE SIZE YOU ASKED FOR

We listened to feedback and designed the GENESIS to fit in the popular standard 210mm / 8.5" type dimensional envelope.

MODELS AVAILABLE

- GENESIS HALOGEN 'SPOT' (100W)
- GENESIS HALOGEN 'WIDE' (100W)
- GENESIS HID 'SPOT' (35W internal ballast)
- GENESIS HID 'WIDE' (35W internal ballast)

HID BULB OPTIONS THAT GIVE YOU MORE!

The HB3 bulb is custom made to our specifications to give optimum performance with our reflector designs. Standard is 5000K 'SUPER WHITE' with 4200K NORMAL and 3200K 'ION YELLOW' as optional extras. Experienced racers understand the benefits of a yellow type light in dust or fog conditions, drastically reducing glare and eye fatigue. Do not be misled by high kelvin ratings 6000+! These actually reduce light output and distance.

LESS THAN HALF THE WEIGHT OF OUR RIVALS

For over twenty years we have been producing the toughest lightest lights on the market and GENESIS is no exception! We are the pioneers of using Hi-Tec composite materials to deliver user benefits like no other. Weight is every racer's enemy, so why add fat when there is a better way? Think about it.

GENESIS HALOGEN: 1.1 kg | 2 lb 6.8oz (single)

GENESIS HID: 1.3kg | 2lb 13.85oz (incl. internal ballast - single)

15% LARGER REFLECTOR SURFACE AREA

At the core of any light's performance is reflector design and quality. Light output is a combined factor of shape, surface finish and relation to the bulb type, position and efficiency. Compared to the majority of lights on the market in this popular size, GENESIS has 15% greater effective reflector surface area! Result? GENESIS delivers more light output for its size.

HARD-COATED 'POLYCARB' LENS

Just like headlights on a many new vehicles we use hard coated polycarbonate for unparalleled impact strength and resistance to scratching. Wash and wipe, no problem! Heavy, toughened glass is simply outdated and illogical design. Why compromise when product failure can lose you the race?

SCULPTURED ALLOY BEZEL

The alloy front bezel acts as a ring of armour and we designed the fixture points at the rear to eliminate debris collecting in the screw holes. This is where the unique 'MBS' brackets attach, more on that below!

MIL SPEC GORE-TEX® BREATHER

Gore-tex® breather (IP57/67/68/IP69K) to protect against moisture ingress.

UNIQUE MOUNTING POSITION OPTIONS

Straight out of the box, the GENESIS gives you four different mounting depth options (fore & aft). The incredibly robust mounting bracket can be flipped either way PLUS we have included two positions on the body itself.

MOUNTING BRACKET SYSTEM (MBS)

After listening to fabricators and trophy truck teams we designed the most comprehensive mounting system available. An optional slotted bracket mounts to the rear of the aluminium front bezel enabling the light to be finely adjusted and locked down. The passivated satin black bracket can be used at the top, sides or all 3 together. Combined with the base bracket that has provision for 3 bolts, some would say overkill, we say it's done right.

ANTI-THEFT KIT OPTIONS

An optional stainless steel cross bolt incorporates a groove that is designed to be engaged by an 'interference' bolt making it virtually impossible to withdraw the cross bolt whilst mounted. Ideally this should be combined with a set of Keith's security nuts creating a formidable theft deterrent system. (>P10)

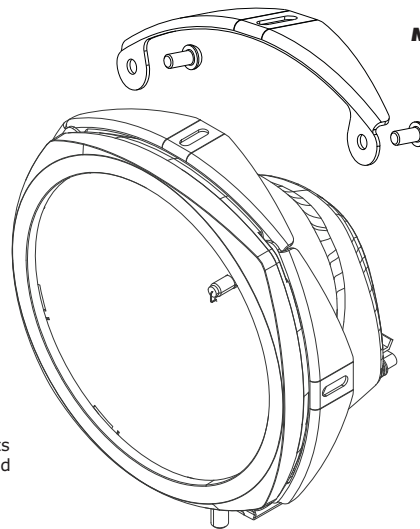
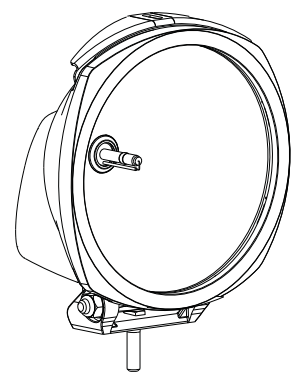
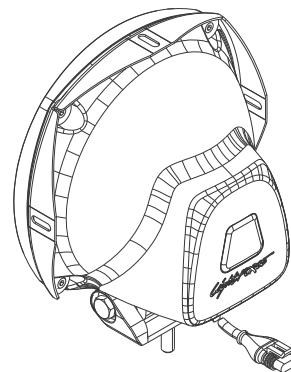
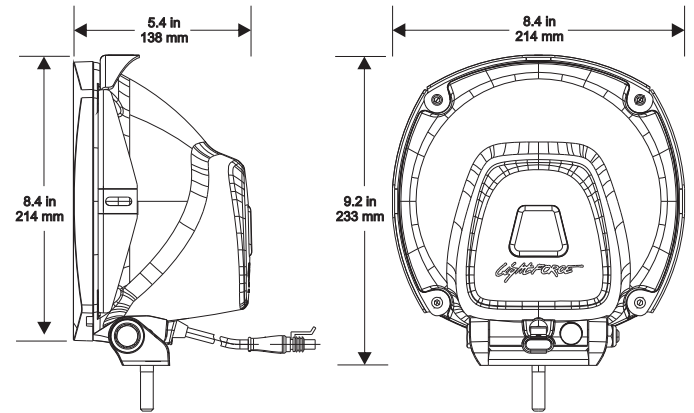

MBS • MOUNTING BRACKET >OPTIONAL ACCESSORY

These brackets may be utilised in a top or side mount configuration to ensure maximum rigidity under the most extreme conditions. The slotted holes help to ensure ease of correct light positioning.

NOTE: These items are sold as single pack items

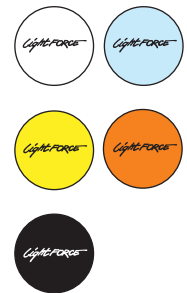

'POLYCARB' FILTERS

Naturally we have included a range of optional clip on polycarbonate filters to customize the light to driving conditions.

- CLEAR • YELLOW • AMBER • CRYSTAL BLUE
- OPAQUE SOLID

SIZE DOES MATTER!

On a full size truck or ute you need a full size light and the 240 series delivers the right look and more. The XGT with its Xenophot® bulb is arguably the best value high performance light available. One step further again is the Baja winning 240 HID. Stellar!

NOT FOR THE MEEK OR MILD MANNERED...

240XGT • POWER & VALUE

The 240 XGT is built on the award winning HID type housing and mounting system incorporating a 12V Xenophot® 100 watt bulb. Without doubt our most popular light and for good reason! The combination of inherent mechanical strength and powerful output have made this the choice for off-road racers and the hardcore enthusiast worldwide.

- Ideal long distance performance light
- 12V 100 watt Xenophot® 2000 hour bulb (24V halogen version available)
- LIGHT OUTPUT (12V) | 730 000 candela | 1 lux @ 900 m
- Lightweight polycarbonate, glass filled nylon composite construction
- Gore-tex® breather (IP57/67/68/IP69K) to protect against moisture/contaminant ingress
- Optional billet focal ring to increase beam width
- Best value for OFF-ROAD motor sport or hardcore enthusiast
- Partner with a set of 170 STRIKERS for ideal spread and scorching distance
- CLEAR SPOT clip-on polycarbonate filter supplied | Others available
- WEIGHT (single unit) 1.37 kg | 3lb .32oz

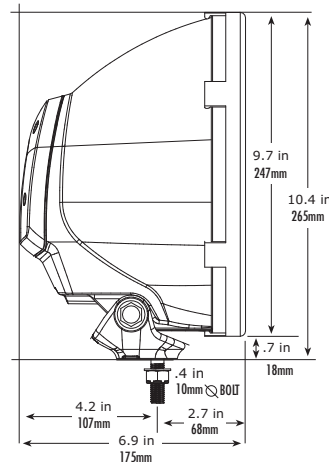

240HID • KING OF THE HILL

We debuted our first 240 HID back in 2001 with the legendary Rod Hall's Team Hummer. That victory and those to follow placed LIGHTFORCE at the elite edge. Design awards, industry and user accolades continue worldwide. No other HID offers the tunability to alter the focal length of the bulb and beam angle as you desire. The parabolic reflector projects the maximum light available and to this day remains arguably one of the most powerful driving lights in the world. Trophy Truck, Class '1' or any cutting edge off-road machine that deserves the best? Your ultimate light awaits.

- Ultimate long range driving light ideal for high speed off-road motorsport
- LIGHT OUTPUT | 1 lux @ > 1200+ m
- Lightweight polycarbonate, glass filled nylon composite construction
- Gore-tex® breather (IP57/67/68/IP69K) to protect against moisture/contaminant ingress
- 12V 35 watt HID (internal ballast - plug 'n play)
- Billet alloy focal rings for customizing beam angle pattern: 9.8° | 11.8°
- CLEAR SPOT clip-on polycarbonate filter supplied | Others available
- WEIGHT (single unit) 1.55 kg | 3lb 6.67oz

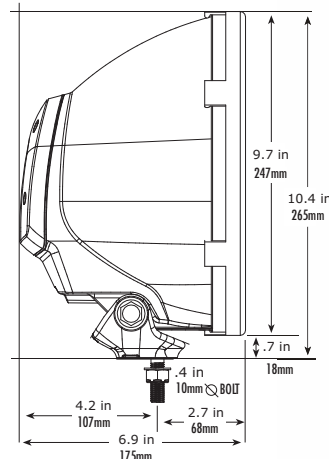

MEET THE OUTBACK LEGENDS!

No matter what your vehicle or driving conditions we have the solution. Available as standard with Xenophot® bulbs giving up to 20% more output than ordinary halogen bulbs. These are the lights that forged LIGHTFORCE's reputation 'outback'.

ORIGINAL XENOPHOT® PERFORMANCE



WE TOOK A LEGENDARY FAMILY, straight to a new level of performance utilising HID technology. Utilising a slim-line 35W ballast, precision billet bulb holder and 5000K bulb results in phenomenal light output. Low amp draw, long bulb life, less heat and unbeatable value!

NEW HID MODELS
 • LANCE • STRIKER
 • BLITZ

SO, YOU HAVE A SET OF RMDL LIGHTS? Upgrade to the power and efficiency of cutting edge HID technology. LIGHTFORCE engineered, ready for a quick easy DIY installation! Choice of 3200°K • 4200°K • 5000°K for the discerning enthusiast.

140 LANCE™ • VERSATILITY PLUS

It may be small, but the 140 LANCE™ can be a wise choice! If you need high performance in a compact package, this is the answer. Off-road comp vehicles often install these as fog, winch, crawling or reversing lights with dispersion filters. Remember with LIGHTFORCE you can customise the colour and beam pattern to driving conditions! Make no mistake, even our smallest light is off-road race ready!

- Compact performance for any size or vehicle type
- 12V 75 watt Xenophot® 4000 hour bulb (maximum wattage) 24V halogen available
- LIGHT OUTPUT | 110 000 candela | 1 lux @ 450 m
- Lightweight polycarbonate, glass filled nylon composite construction
- Gore-tex® breather (IP57/67/68/IP69K) to protect against moisture/contaminant ingress
- Ideal as a fog light (with opt. YELLOW / AMBER filter) or off-road reversing light
- Ideal for use as a winch light with a DISPERSION filter
- CLEAR SPOT clip-on polycarbonate filter supplied | Others available
- WEIGHT (single unit) 460g | 1lb .2oz

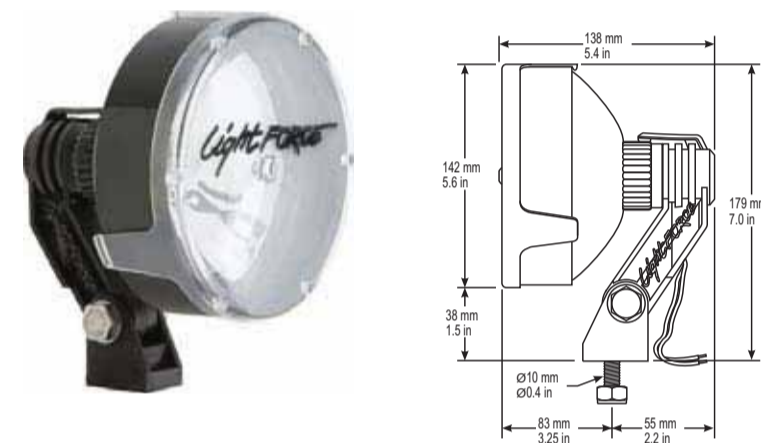

170 STRIKER™ • GIANT 'KILLA'

The mid-size 170 STRIKER™ outperforms many larger lights and is one of our most popular models worldwide. Its compact size makes it an easy install on most vehicles and with a set of COMBO or SPREAD filters it is incredibly versatile creating an ideal peripheral light pattern. Many race vehicles are equipped with a set of STRIKERS for their fill type output complementing either the larger BLITZ/XGT or HID light for pure scorching distance.

- Compact performance but with optimum reflector size outperforming larger rivals
- 12V 100 watt Xenophot® 2000 hour bulb (24V halogen version available)
- LIGHT OUTPUT (12V) | 350 000 candela | 1 lux @ 650 m
- Lightweight polycarbonate, glass filled nylon composite construction
- Gore-tex® breather (IP57/67/68/IP69K) to protect against moisture/contaminant ingress
- Light output can be tailored from a WIDE, COMBO or long distance SPOT pattern
- Ideal additional light partnered with 240 BLITZ / XGT / HID for off-road motorsport
- CLEAR SPOT clip-on polycarbonate filter supplied | Others available
- WEIGHT (single unit) 560g | 1lb 3.75oz

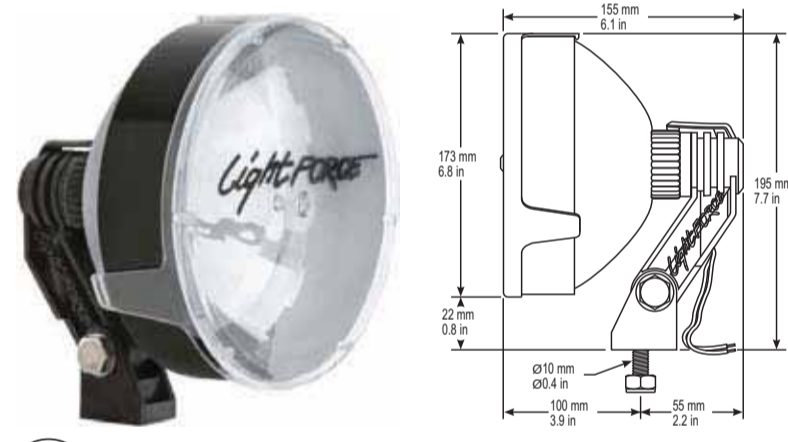

E2 EMARK model compliance #HR PL 30 E2 0007091 • H1 12/24V 55/70W
 NOTE: If spacer removed or higher wattage bulb used, light will not be compliant.

240 BLITZ™ • OUTBACK LEGEND

The 240 BLITZ™ was our first true long distance light and began our reputation for high performance and light intensity. It was not long before it became a favourite in the heavy transport, freight industry in Australia, Europe and Alaska. The combination of extreme light output, lack of vibration and durability made it standard equipment in many commercial fleets. If you desire long distance, power and value for money, the 240 BLITZ is certainly worth considering.

- Ideal long distance performance light
- 12V 100 watt Xenophot® 2000 hour bulb (24V halogen version available)
- LIGHT OUTPUT (12V) | 730 000 candela | 1 lux @ 900 m
- Lightweight polycarbonate, glass filled nylon composite construction
- Gore-tex® breather (IP57/67/68/IP69K) to protect against moisture/contaminant ingress
- CLEAR SPOT clip-on polycarbonate filter supplied | Others available
- WEIGHT (single unit) 880g | 1lb 15oz

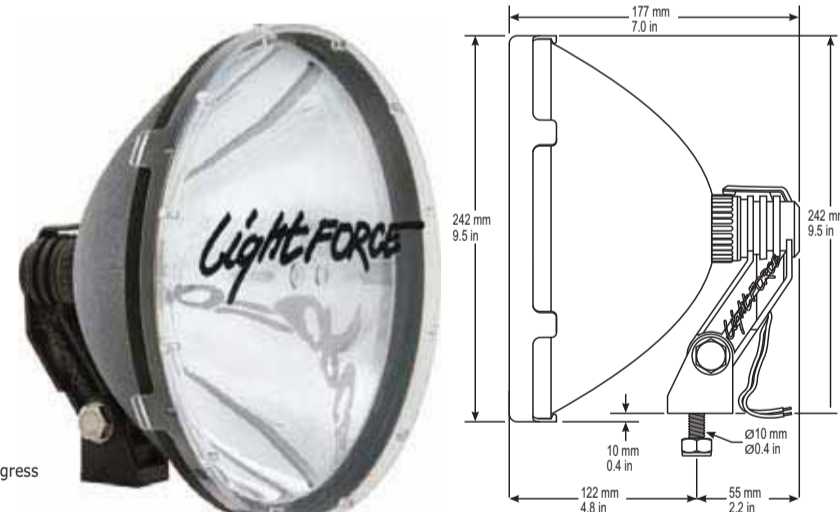

E2 EMARK model compliance #HR PL E2 0006027-27.5 • H1 12/24V 55/70W
 NOTE: If spacer removed or higher wattage bulb used, light will not be compliant.



A NEW ERA IS BORN

The Lightforce Lance, Striker and Blitz driving lights are now available in a HID configuration direct from Lightforce. Customers can have peace of mind that these have been specifically designed for maximum light output and durability.

240 BLITZ™ HID SLEDGEHAMMER PERFORMANCE

The 240 BLITZ™ HID offers a performance level suited for those who require extreme long distance visibility such as professional remote long haul truck drivers etc. When focussed to it's tightest spot there are few lights in the world that can compete when distance does matter. For the budget conscious offroad motorsport enthusiast who desires maximum lighting horsepower... Your light has been served.

170 STRIKER™ HID A WOLF IN SHEEP'S CLOTHING

The 170 STRIKER already has many fans but wait until you see it perform in its HID pedigree. Despite its compact size, the combination of parabolic reflector and HID intensity projects a beam that sends many competitor's larger lights running for cover. Its versatility makes it perhaps the consummate all rounder equally at home on a touring vehicle or pure bred race machine.

140 LANCE™ HID DON'T LET ITS SIZE FOOL YOU

The LANCE in HID format is redefining conventional beliefs of performance in a compact light. Ideally suited for motorcycles, ATVs, UTVs or smaller type vehicles or confined installation spaces. Combined with the versatility of standard 'RMDL' family features, the LANCE HID is rapidly evolving its own cult following for the discerning enthusiast.



Precision billet bulb holder positions specially design LIGHTFORCE bulb. Compact slim-line ballast with 1.2 metre lead allows remote secured mounting.

THE QUALITY IS IN THE DETAIL

- The bulb has been designed by LIGHTFORCE exclusively for use with our RMDL range of products. This unique LIGHTFORCE bulb reduces the shadow "V" line common in aftermarket kits.
- Focal point of bulb is optimised to suit the Lightforce parabolic reflectors.
- Assembled lights come in pairs, fitted with 5000k bulbs in 12 or 24 volt.
- Optional bulbs available: 3200°K Ion Yellow (minimises glare in fog or dust) and 4200°K Natural White (used in our DL240HID) this is also the standard colour temp for the automotive industry.
- Long 1.2 metre lead between ballast and the driving light allows remote secured mounting for improved theft prevention.
- Fully sealed and waterproof.
- Compact slim-line ballast
- Waterproof connectors.
- Billet aluminium bulb holder with distinctive blue anodised finish.

Part Numbers – RMDL HID DRIVING LIGHT assembled lights

- HID140T Lance 140mm** - HID twin pack 12V 35W remote ballast 5000°K
- HID140T2 Lance 140mm** - HID twin pack 24V 35W remote ballast 5000°K
- HID170T Striker 170mm** - HID twin pack 12V 35W remote ballast 5000°K
- HID170T2 Striker 170mm** - HID twin pack 24V 35W remote ballast 5000°K
- HID240T Blitz 240mm** - HID twin pack 12V 35W remote ballast 5000°K
- HID240T2 Blitz 240mm** - HID twin pack 24V 35W remote ballast 5000°K

GENUINE LIGHTFORCE RETRO-FIT HID KIT

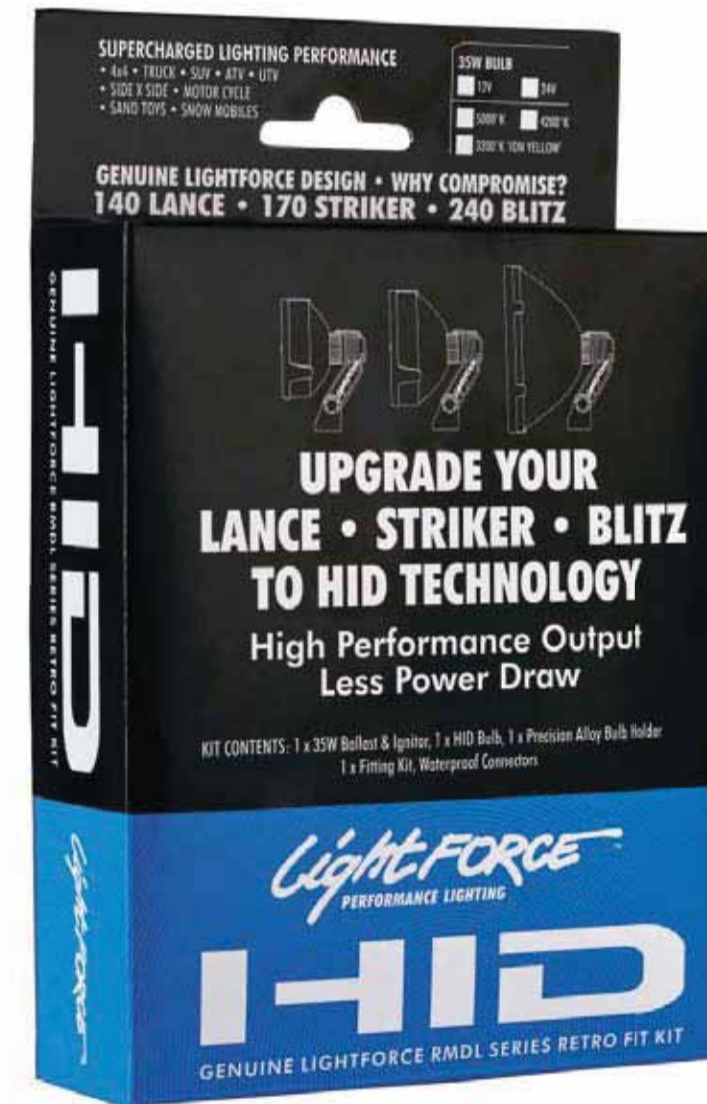

TRANSFORM YOUR EXISTING RMDL LIGHTS TO A NEW LEVEL OF LIGHTING PERFORMANCE!

The easy to install kit contains the exact same complementary as our ready to buy RMDL HID SERIES. Many 'conversion' kits in the market place compromise quality and design integrity resulting in less than optimum performance. As we say on the previous page, the quality is in the detail. With the genuine LIGHTFORCE kit you are 'race ready' guaranteed.

Part Numbers - HID UPGRADE KITS

- RMKIT32 HID Upgrade Kit** to suit single RMDL 12V 35W 3200°K Ion Yellow
- RMKIT42 HID Upgrade Kit** to suit single RMDL 12V 35W 4200°K Natural White
- RMKIT50 HID Upgrade Kit** to suit single RMDL 12V 35W 5000°K Super White
- RMKIT2-32 HID Upgrade Kit** to suit single RMDL 24V 35W 3200°K Ion Yellow
- RMKIT2-42 HID Upgrade Kit** to suit single RMDL 24V 35W 4200°K Natural White
- RMKIT2-50 HID Upgrade Kit** to suit single RMDL 24V 35W 5000°K Super White



CUSTOMIZE YOUR LIGHT IN SECONDS

Without any tools you can clip-on a filter and change the beam and or colour to have the ideal light for any conditions. Safety and versatility makes this concept a clear market winner. See better. Drive safer.

CLIP-ON FILTERS GIVE YOU MORE VERSATILITY

MODULAR FILTER SYSTEM

Made of polycarbonate, our filters are able to withstand impacts that literally can leave our opposition in pieces! Polycarbonate is used in fighter aircraft canopies, security screens etc. Our system even includes infra-red as supplied to the military and law enforcement agencies for covert operations with night vision gear. It's a tough world out there and LIGHTFORCE is sought after for its unique performance where the majority fail.

SPOT: Every light is supplied with a CLEAR SPOT filter. This allows maximum distance and via various colours allows you to quickly change to suit driving conditions.

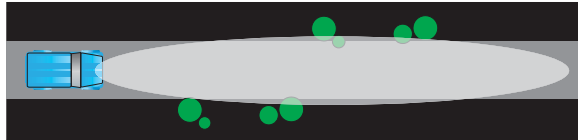

COMBO: The COMBO gives a wide beam pattern plus the bonus of long distance all in one. This is fast becoming the most popular LIGHTFORCE accessory worldwide!

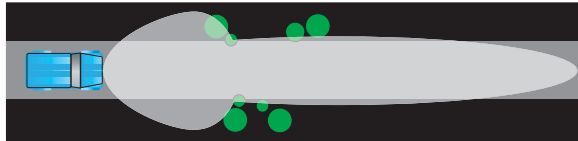

WIDE: The WIDE angle maximises the beam spread giving broad peripheral vision. This enables you to see potential hazards and enhances your driving safety and performance.



DISPERSION: Giving a highly diffused wall of light, it is ideal for vehicle recovery, winching, rock crawling or slow tight terrain where distance is not a factor. Customize your light to suit the conditions!

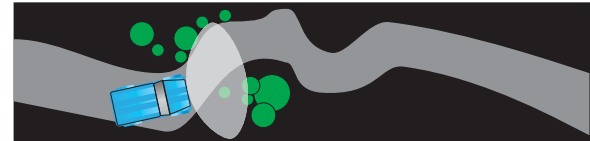

SPOT 140 170 240	COMBO 170 240	WIDE ANGLE 140 170	DISPERSION 140 170
CLEAR Supplied as standard.	CLEAR	CLEAR	*CLEAR
YELLOW FOG SILT HAZE DUST	YELLOW FOG SILT HAZE DUST	YELLOW FOG SILT HAZE DUST	
CRYSTAL BLUE INCREASED CLARITY	CRYSTAL BLUE INCREASED CLARITY	CRYSTAL BLUE INCREASED CLARITY	
SNOW BLUE SNOW RAIN SEA SPRAY	SNOW BLUE SNOW RAIN SEA SPRAY		
AMBER OFFROAD SILT HAZE DUST	AMBER OFFROAD SILT HAZE DUST		
BLACK (SOLID OPAQUE) PROTECTIVE			
*INFRA-RED (COVERT) MILITARY/POLICE/SECURITY (NOTE): Requires night vision equipment			

* All filters include a printed LIGHTFORCE logo except for the DISPERSION and INFRA-RED versions

FORGED IN THE AUSTRALIAN OUTBACK
 LIGHTFORCE driving lights have always had the reputation for long distance performance. Professional drivers recognise the advantages in safety and reduced running costs due to product durability over other brands.

SEE HOW LIGHTFORCE MEASURES UP

LUX, THE REAL MEASURE

Here you can clearly see the distances each model is capable of when set up as a spot configuration as supplied. Realise that the quality of light as you see it is what is important.

Driving conditions, terrain and individual's eyesight all play a role in the optimum setup. At LIGHTFORCE, we understand this and give you the options to achieve safer night time driving be it racing, hauling freight or just getting your family home safely.

LUX is an ideal real world measure that is easy to understand unlike often misleading candlepower claims. Simply, 1 LUX is sufficient illumination to read a newspaper or to effectively illuminate medium contrast objects. (i.e. fauna, livestock, signs, etc)

We recommend utilising a premium quality LIGHTFORCE wiring harness and a qualified installer to ensure maximum performance and long term reliability.

Please check your local regulations concerning the installation and operation of auxiliary automotive lighting for use on public roads.

NOTE: The following diagrams are graphic representations only of comparative light output in metres of LIGHTFORCE driving light models. The beam was focussed to a 'SPOT' pattern to achieve maximum distance for a reading of 1 LUX.

1 LUX is defined in real terms as being sufficient light to read a newspaper.

Actual distance achieved may differ due to vehicle installation, wiring, atmospheric conditions and voltage.

TECHNICAL SPEC OVERVIEW

Below you will see a quick reference chart comparing the current range of lights. As you can see all our products are extremely lightweight reflecting our design criteria. Remember heavyweight lights are not by default stronger and indeed may induce vibration and cause secondary issues. It's all about smart design!

MEASURE THE REFLECTOR DIAMETER, NOT THE OUTSIDE HOUSING.

When assessing a light's maximum distance capability consider the reflector diameter, the larger the effective size the greater the potential light output. Even our compact STRIKER™ has a larger reflector than some of its larger rivals. Remember it's the combination of how the reflector utilises the bulb output... SIMPLE, but often overlooked! Take a minute to look at all the factors when assessing any driving light.

MODEL	POWER	REFLECTOR ACTUAL DIAMETER
140 LANCE™	12V • 75W	128mm • 5.04"
170 STRIKER™	12V* • 100W	164 mm • 6.46"
240 BLITZ™	12V* • 100W	230 mm • 9.06"
240 XGT	12V* • 100W	230 mm • 9.06"
240 HID	12V • 35W HID	230 mm • 9.06"

NOTE: * 24V bulb available
 EMARK 170/240 fitted with 55/70W 12V/24V respectively

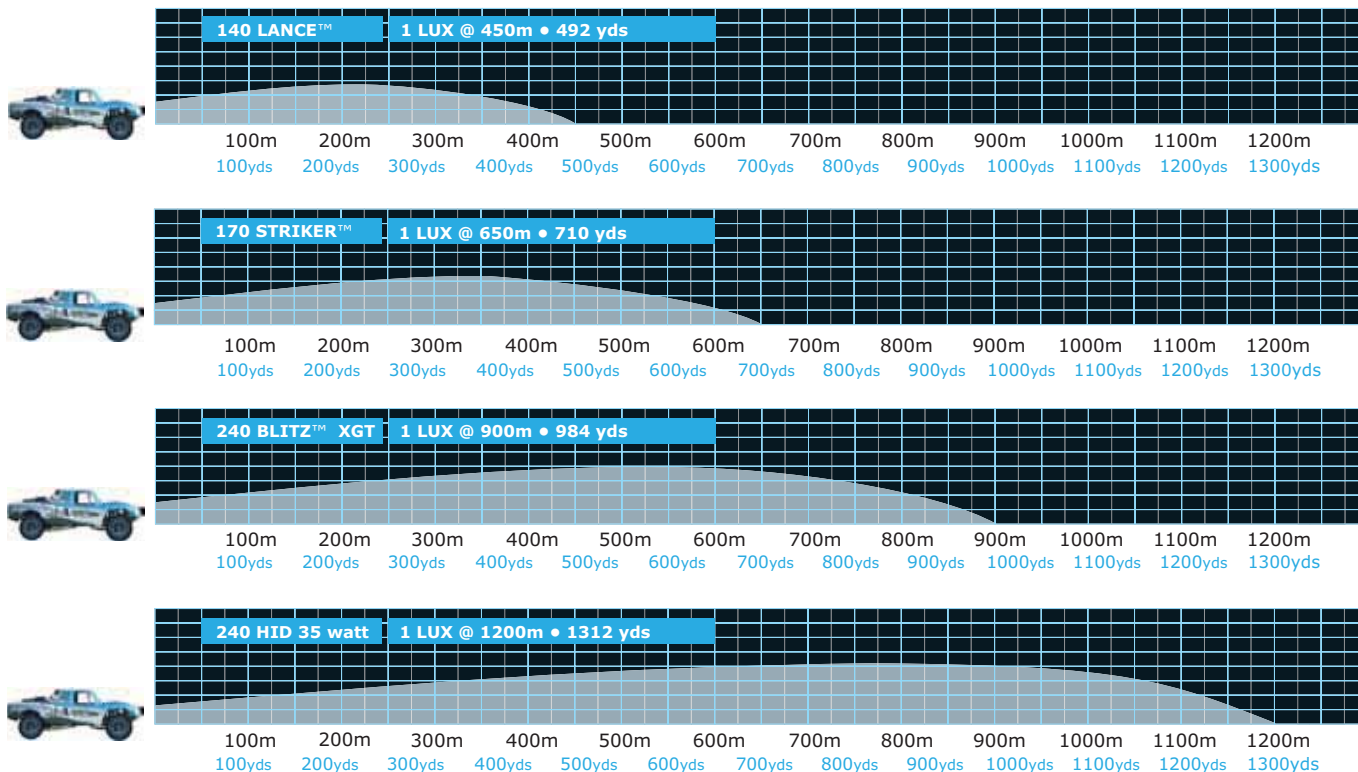

NOTE: Voltage calculated as being 12V at the bulb supplied via a regulated power supply.



LIGHTFORCE ACCESSORIES

We have you covered from a quality wiring harness, security nuts and even a quick install light bar. Also available is the ENFORCER portable spotlight that has become the choice for many police, search/rescue and military groups worldwide.

MUCH MORE THAN JUST DRIVING LIGHTS

LIGHTFORCE WIRING HARNESS

The LIGHTFORCE wiring harness assists in convenient installation and maximizing performance from your LIGHTFORCE or any other driving lights on your vehicle. A quality wiring harness and installation is crucial to reliability and optimum light output.

- Resistor protected 30A relay
- Waterproof blade fuse holder
- Extra long cables (for larger vehicles)
- All required terminals
- Can be POSITIVELY or NEGATIVELY switched to suit some imported vehicles (Refer included instructions for comprehensive detail)
- Comprehensive easy to understand instructions

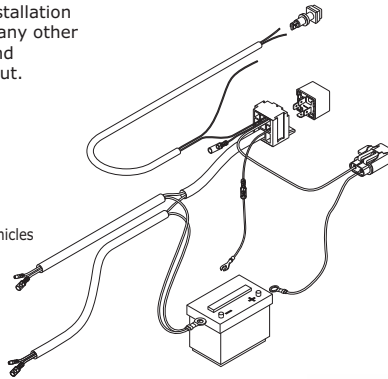

SECURITY NUTS

Well these are the next best thing to having a kangaroo standing by your vehicle with a cricket bat. The simple to install security nuts will help protect your investment against opportunist 'LIGHT' fingered thieves. Each kit consists of two half dome coded nuts and one keyed socket requiring a 21 mm, 13/16" spanner. These nuts will fit all LIGHTFORCE driving lights and other lights using a 10 mm bolt (M10 x 1.5).



LIGHTFORCE LIGHTBAR

This provides the easiest method to install a set of LIGHTFORCE driving lights. It is designed to simply bolt in place behind your license plate in just a few minutes! For compact cars or light duty off road work, the LIGHTBAR provides the ideal solution!



ENFORCER • PORTABLE POWER

The ENFORCER is a feature packed portable searchlight system. We have sold thousands worldwide to the military, law enforcement and professional utilities groups. Supplied as a kit, the unit can be instantly converted between cordless (2.7 A/h NiMh) battery and coil cord operation (12V) from a vehicle. The 30W high efficiency bulb is complemented by a 3 LED system for a soft work light with extended run time. The ENFORCER is no pretender, it's the real deal.

- 170 mm parabolic reflector for maximum distance performance
- 30W high efficiency bulb plus 3 LEDs for a work light mode
- Ergonomic Hi-Tec composite housing and handle designed for PRO use
- 12/24V vehicle charger included in sturdy fitted carry case (Mains charger dependent on region)



LIGHTFORCE TESTING GROUNDS

A crucial factor in our success has been networking with our customers and international off-road community. This gallery illustrates the diversity of cutting edge vehicles choosing to install Lightforce for similar reasons. They recognized the advantages of Lightforce over every other brand they have previously used.

GALLERY

LIGHTFORCE COMMUNITY AT ITS BEST





WE HOPE YOU HAVE FOUND THIS GUIDE USEFUL

If you have any further questions please ask your stockist or feel free to contact us direct by email. As we are the designer and manufacturer we are in a unique position to assist you in making a very important purchasing decision. Afterall, your driving safety is not something to be compromised.

Email enquiries: info@lightforce.net.au

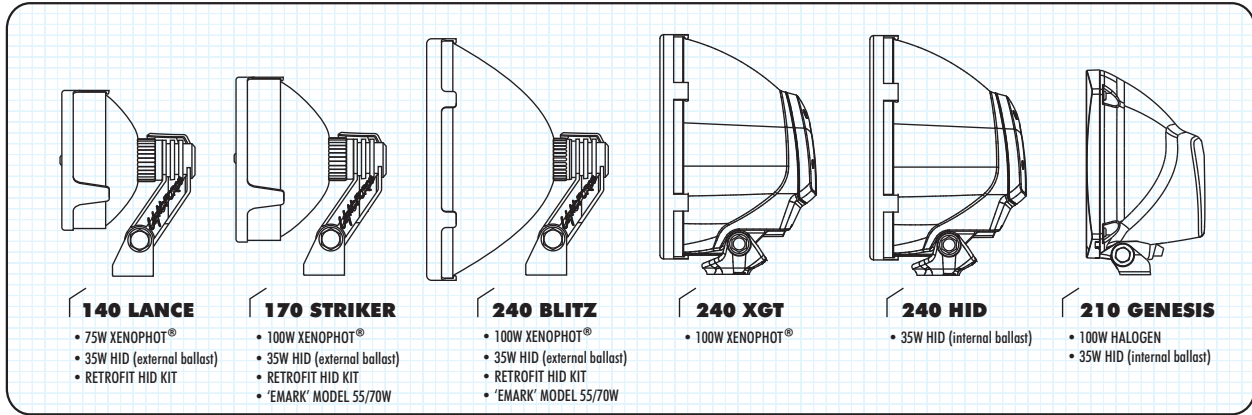

MODEL	SIZE - H x W x D - metric	SIZE - H x W x D - imp	UNIT WEIGHT	WATTS	BULB TYPE	12 VOLT	24 VOLT	Ballast Location	Gore-tex® Breather	Stainless Fittings	MBS*** Bracket
140 LANCE	179mm x 142mm x 138mm	7.0" x 5.6" x 5.4"	460g 1lb .2oz	75*	XENOPHOT®	GL05	GL12	N/A	YES	YES	N/A
170 STRIKER	195mm x 173mm x 155mm	7.7" x 6.8" x 6.1"	560g 1lb 3.75oz	100	XENOPHOT®	GL02	GL13	N/A	YES	YES	N/A
240 BLITZ	242mm x 242mm x 177mm	9.5" x 9.5" x 7.0"	880g 1lb 15oz	100	XENOPHOT®	GL02	GL13	N/A	YES	YES	N/A
140 LANCE HID	179mm x 142mm x 138mm	7.0" x 5.6" x 5.4"	460g 1lb .2oz	35	High Intensity Discharge	HID 5000**	HID 5000**	EXTERNAL	YES	YES	N/A
170 STRIKER HID	195mm x 173mm x 155mm	7.7" x 6.8" x 6.1"	560g 1lb 3.75oz	35	High Intensity Discharge	HID 5000**	HID 5000**	EXTERNAL	YES	YES	N/A
240 BLITZ HID	242mm x 242mm x 177mm	9.5" x 9.5" x 7.0"	880g 1lb 15oz	35	High Intensity Discharge	HID 5000**	HID 5000**	EXTERNAL	YES	YES	N/A
170 LANCE EMARK****	195mm x 173mm x 155mm	7.7" x 6.8" x 6.1"	560g 1lb 3.75oz	55/70	Halogen	H1	H1	N/A	N/A	N/A	N/A
240 BLITZ EMARK****	242mm x 242mm x 177mm	9.5" x 9.5" x 7.0"	880g 1lb 15oz	55/70	Halogen	H1	H1	N/A	N/A	N/A	N/A
240 XGT	265mm x 247mm x 175mm	10.4" x 9.7" x 6.9"	1.37kg 3lb .32oz	100	XENOPHOT®	GL02	GL13	N/A	YES	YES	CUSTOM ORDER*
240 HID	265mm x 247mm x 175mm	10.4" x 9.7" x 6.9"	1.55kg 3lb 6.67oz	35	High Intensity Discharge	HID 4200**	HID 4200**	INTERNAL	YES	YES	CUSTOM ORDER*
210 GENESIS SPOT HALOGEN	233mm x 214mm x 138mm	9.2" x 8.4" x 5.4"	1.1kg 2lb 6.8oz	100	HALOGEN	HB3	HB3	N/A	YES	YES	YES
210 GENESIS WIDE HALOGEN	233mm x 214mm x 138mm	9.2" x 8.4" x 5.4"	1.1kg 2lb 6.8oz	100	HALOGEN	HB3	HB3	N/A	YES	YES	YES
210 GENESIS SPOT HID	233mm x 214mm x 138mm	9.2" x 8.4" x 5.4"	1.3kg 2lb 13.85oz	35	High Intensity Discharge	HID 5000**	HID 5000**	INTERNAL	YES	YES	YES
210 GENESIS WIDE HID	233mm x 214mm x 138mm	9.2" x 8.4" x 5.4"	1.3kg 2lb 13.85oz	35	High Intensity Discharge	HID 5000**	HID 5000**	INTERNAL	YES	YES	YES

NOTE: Specifications and metric-imperial conversions have been calculated with due care however LIGHTFORCE reserves the right to change data/components without notice.

* 75 watt bulb is maximum wattage that maybe fitted to any LIGHTFORCE 140mm sized light

** 5000°K fitted as standard. 3200°K 'ion yellow' & 4200°K available as optional accessories

*** 'MBS' bracket is an optional accessory for extreme off-road motor sport use enabling the light to be braced against any possible independent movement. This is not required for general use.

**** EMARK version is available in 12V 55W and 24V 70W configuration

^ CUSTOM ORDER (USA only): This bracket enables a 'heim' type attachment to the 12 o'clock position of the 240XGT or 240HID. This requires custom fabrication and is available special order only

DEALER NOTES

.....

.....

.....

.....

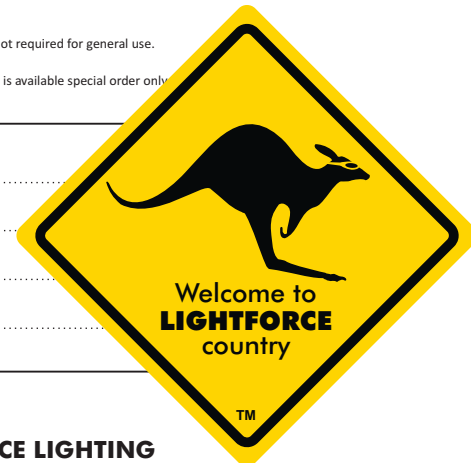

Head Office: Australian & International enquiries

LIGHTFORCE AUSTRALIA

28 Orsmond Street
Hindmarsh SA 5007
Australia

Tel: 08 8440 0888 Int'l Tel: +61 8 8440 0888
Fax: 08 8346 0504 Int'l Fax: +61 8 8346 0504

lightforce.com
info@lightforce.net.au

USA enquiries

LIGHTFORCE PERFORMANCE LIGHTING

208 Jason Court
Corona CA 92879
USA

Tel: 714-460-4247
Fax: 714-475-5025

lightforce.com
usasales@lightforce.com



Product specifications and content subject to change without notice. All logos, trademarks, images property of LIGHTFORCE Australia Pty Ltd or respective owners © JUL2008
No part of this maybe reproduced without permission from LIGHTFORCE Australia Pty Ltd. Products depicted may not be legal for on road use in certain regions.

Forged in the Australian outback. Welcome to LIGHTFORCE country. www.lightforce.com